

SPRAGUE

OPERATING MANUAL

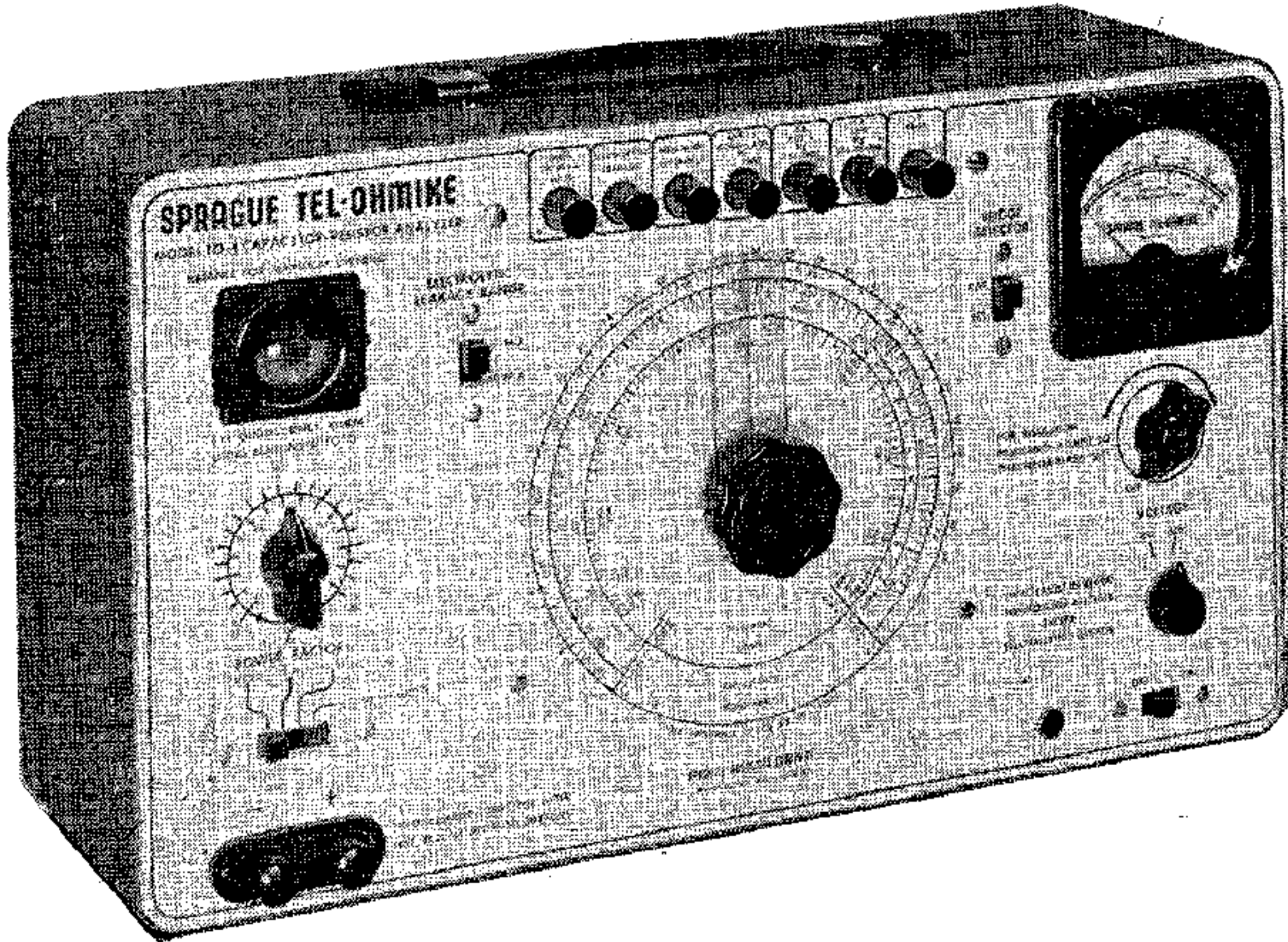

MODEL TO-4 TEL-OHMIKE[®]

CAPACITOR ANALYZER
and RESISTANCE BRIDGE

SPRAGUE PRODUCTS COMPANY

North Adams, Mass.

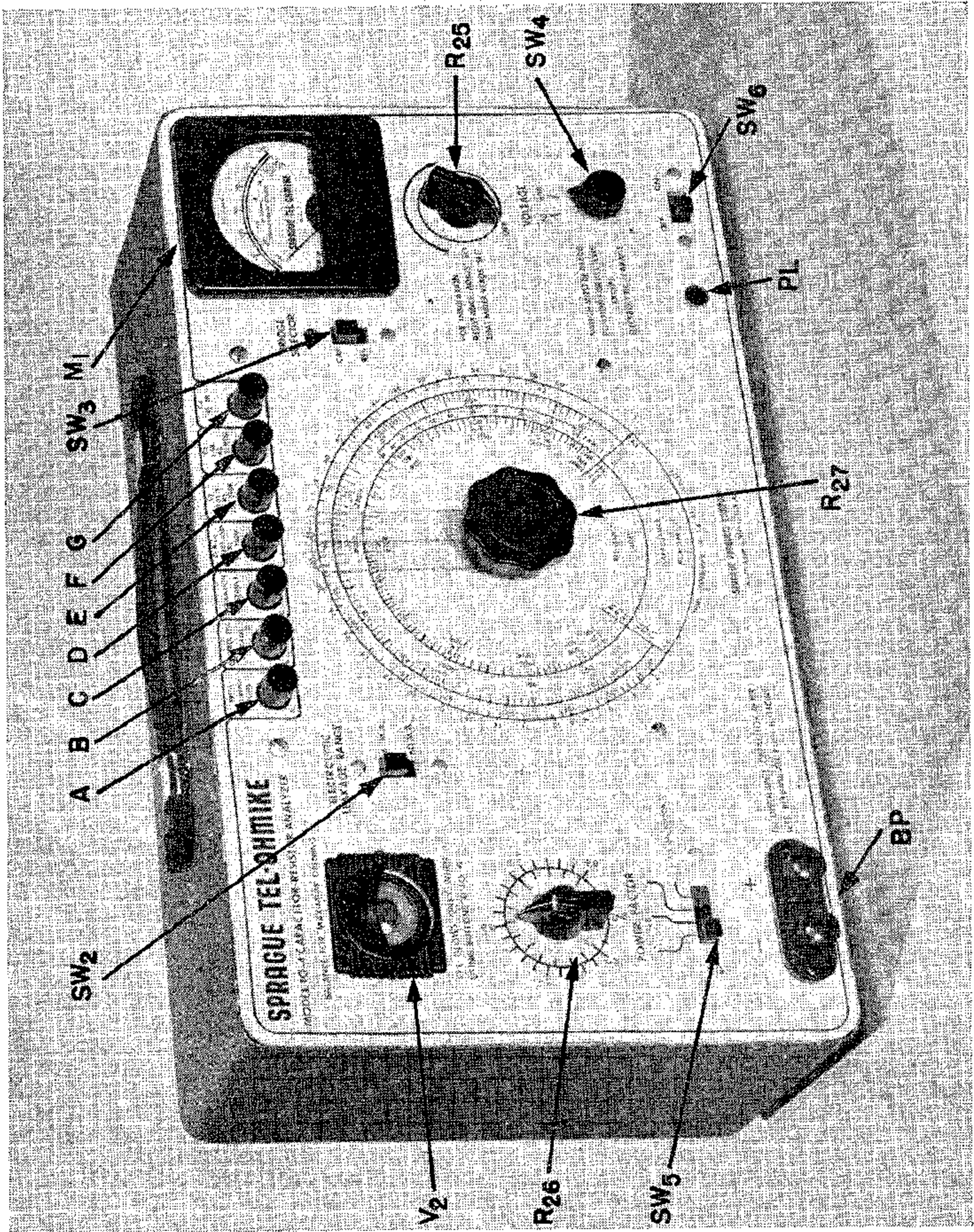

Operating Manual

MODEL TO-4

TEL-OHMIKE ANALYZER



1. General Description

1.1 Purpose and Usefulness. Designed specifically to meet the need of television and radio technicians for a compact, reliable, and simple-to-use instrument for testing all types of capacitors, the Sprague Model TO-4 Tel-Ohmike represents the culmination of years of experience in this field. It incorporates in one instrument an accurate multi-range capacitance and power factor bridge, an insulation resistance checker for paper, mica, and ceramic capacitors, a leakage current test circuit for electrolytic capacitors, and a a-c resistance bridge for measuring resistors. Pushbuttons are provided for instant range selection and a magic-eye tube simplifies bridge balancing for capacitance and resistance measurements. A large meter gives direct pointer readings of insulation resistance and leakage current and shows the exact voltage applied to electrolytic capacitors during the leakage test.

1.2 Three especially valuable features of the Model TO-4 Tel-Ohmike are the extended insulation resistance test range up to 20,000 megohms, the special low capacitance bridge circuit for checking low value ceramic and mica capacitors from 1 mmf to 100 mmf with improved accuracy, and the automatic discharging of capacitors after test by a simple release of all push buttons.

1.3 Capacitance. In addition to the special low range mentioned above, 4 other capacitance ranges are provided for measurements up to 2000 mf. With a TO-4 Tel-Ohmike you are prepared for every capacitor from tiny ceramics and micas to paper capacitors to all types of dry electrolytics from small filter capacitors to extremely high capacitance low-voltage units and motor-starting capacitors.

1.3.1 Power Factor. The power factor of all electrolytics is indicated directly on a scale. Three ranges are provided for improved accuracy of reading.

1.4 Leakage Current. A self-contained continuously adjustable d-c power supply permits measurement of electrolytic capacitor leakage current at exact rated voltage.

1.5 Insulation Resistance. The electronic measurement circuit reads I-R directly from 150 to 20,000 megohms, covering the wide range necessary for testing ceramic, mica, air, and paper capacitors. With a Model TO-4 Tel-Ohmike it becomes a simple matter to detect "leaky" coupling capacitors.

1.6 Resistance. Three ranges are provided for line-frequency bridge measurement of resistors from 2.5 ohms to 25 megohms.

1.7 Line Voltage and Frequency. The Model TO-4 Tel-Ohmike is available in two types. The standard TO-4 is intended for 115 volt, 50-60 cycle a-c lines. Also available is the Model TO-4X for use on 115/230 volt, 25-60 cycle mains. Before using a Model TO-4X, check to see whether the link on the internal terminal plate is in the proper position for the line voltage on which the instrument will be used.

1.7.1 Not For Use on Direct Current. Under no circumstances should a Tel-Ohmike be plugged into a d-c outlet. Always use an inverter power supply (either rotary or vibrator type) to supply the required 35 watts of a-c.

1.8 Physical Appearance. The medium gray wrinkle finish steel case, with leather carrying handle, and the light gray panel with black and red markings make the Model TO-4 an instrument to attract favorable attention and command respect on every service bench. The overall size of the Tel-Ohmike is $8\frac{7}{8}$ in. high by $14\frac{5}{8}$ in. wide by $6\frac{1}{8}$ in. deep.

1.9 Weight. The net weight of the TO-4 is $12\frac{1}{2}$ pounds; of the TO-4X is 14 pounds.

1.10 Electron Tubes. The electron tube complement of each Tel-Ohmike consists of 1 each: 12J5GT, 1619, 1629.

1.11 Components. The components used in the TO-4 were chosen for both suitability and dependability. Molded Telecap paper capacitors are used wherever practical. Ceramic trimmer capacitors and stabilized silver mica capacitors are used as low-capacitance standards, and especially impregnated insulation is used on switches where moisture absorption might be detrimental. Metal parts are treated to resist corrosion, wherever necessary.

2. Capacitance and Power Factor

2.1 Measurements of capacitance from 1 mmf to 2000 mf are made on a 5-range line frequency capacitance bridge. Figure 1 shows a simplified circuit diagram of the bridge employed for the C_1 , C_2 , and C_5 ranges. Figure 2 shows the basic bridge circuit for the C_3 range and Figure 3 is the simplified circuit for the C_4 range. Since the bridge is balanced on all ranges by continuously varying the ratio arm, a highly accurate, linear-taper wirewound variable resistor is used for the main bridge element, R_{27} . These potentiometers are especially selected in order to assure accurate matching of the calibrated scales over their full length. The standard capacitors for the C_1 and C_5 ranges are silvered mica capacitors paralleled by silvered ceramic trimmer capacitors which are factory adjusted to compensate for variations in the inherent wiring capacitance. The standard on the C_2 range is a matched pair of molded Black Beauty Telecap® paper tubulars while the standard on the high capacitance C_3 and C_4 ranges is a matched pair of special paper capacitors. The bridge balance or null detector is a high sensitivity "magic-eye" 1629 tube.

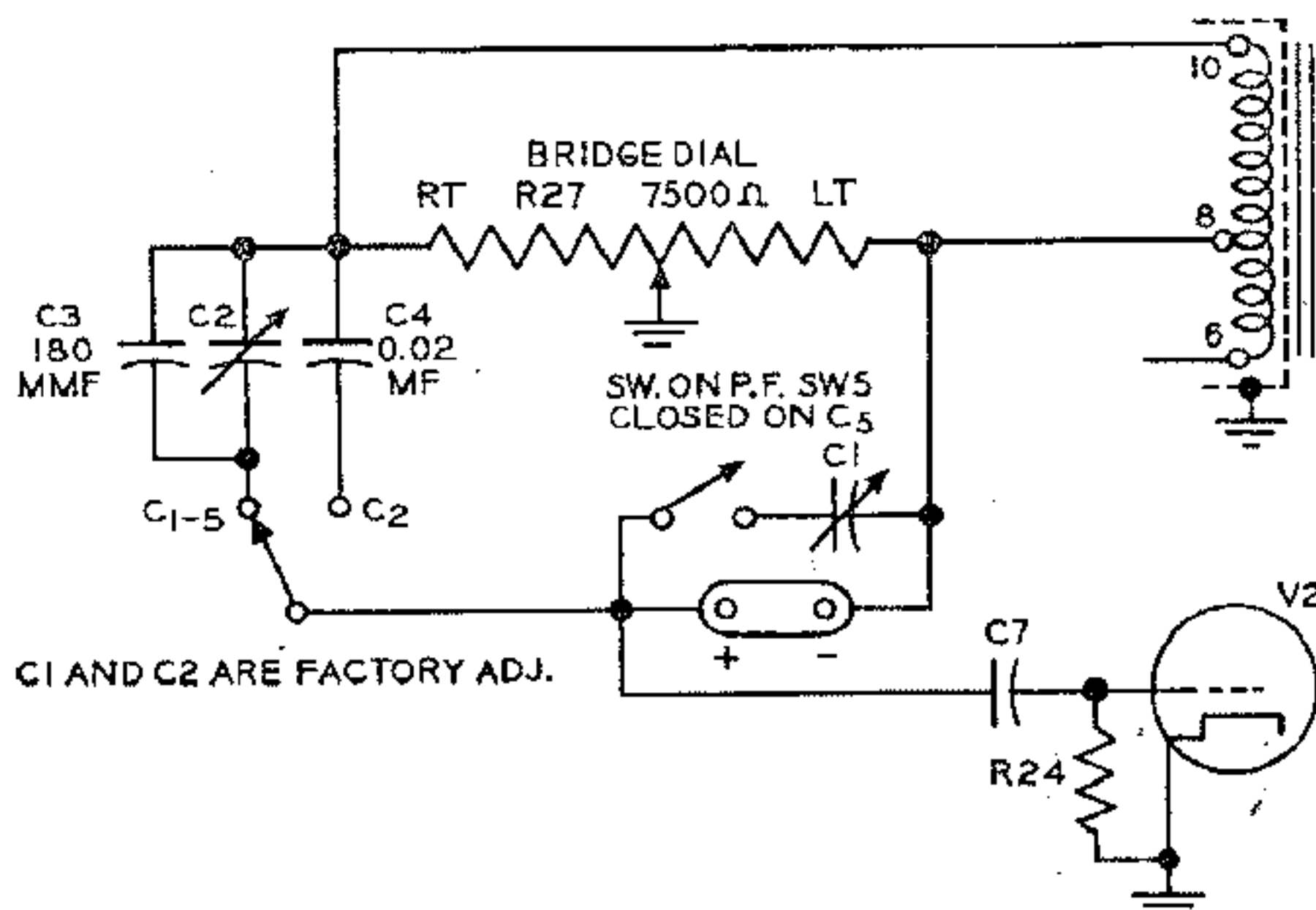

FIGURE 1

Basic Low Capacitance Bridge Circuit for Ranges C_5 , C_1 , and C_2 .

2.2 Operating Procedure

- (1) Depress the proper pushbutton and set the switch under the power factor control as shown below:

Capacitance	Button	P-F Switch	Read on Scale
1-100 mmf	D	C ₅	C ₅
.0001-.005 mf	D	0-20	C ₁
.001-.5 mf	E	0-20	C ₂
.1-50 mf	F	0-20	C ₃
45-2000 mf	G	0-20	C ₄

Note: 1,000,000 mmf = 1 mf

- (2) Set bridge selector switch to CAP. position.
- (3) Place voltage switch in the 600 position.
- (4) Set the a-c line switch in the lower right hand corner of the panel in the "ON" position.
- (5) Connect the capacitor under test to the binding posts at the lower left of the panel. Small ceramic, mica, and paper tubulars should be connected directly across the terminals without using external test leads; otherwise accuracy will be impaired. Observe polarity markings when connecting electrolytics.
- (6a) Slowly rotate the main bridge pointer in a clockwise direction from left to right until a shadow appears in the eye tube at the upper left. Carefully adjust the control for maximum eye opening. Read the indicated capacitance directly from the proper dial scale.
- (6b) For electrolytic capacitors, balance the bridge as in (6a). Then adjust the power factor knob for maximum eye opening. Now readjust the main dial, then the power factor knob, etc. until maximum eye opening is definitely obtained. If this is not possible, try moving the power factor slide switch to the 20-40% or 40-55% positions and proceed as before. When maximum shadow angle is reached, read the capacitance from the main dial scale and the power factor from the proper power factor scale, according to the slide switch setting. When using line frequencies of 50 cycles, multiply the indicated p-f reading by .84; of 40 cycles, by .72; and of 25 cycles, by .46.
- (6d) When it is necessary to measure capacitors without removing them from a chassis, always unsolder one lead from the circuit. Take care not to damage small micas and ceramics with too much heat. To improve the accuracy of measurements on capacitors of less than about 1000 mmf under these conditions, first measure the capacitance of the test leads arranged as they would be when connected except for tying on the test clips. Record the reading. Now connect the clips directly across the capacitor and rebalance the bridge. Deduct the test lead capacitance from this reading to get the capacitance of the unit under test.
- (6e) Capacitors which can be balanced only at the right hand (clockwise) end of the scales on all ranges are open and should be discarded. Capacitors balancing only on the high (counterclockwise) end of the scales are short-circuited and should be discarded. Capacitors with "intermittents" will cause a marked flickering of the magic eye indicator and should be replaced.
- (6f) Some capacitors in television receivers are rated in terms of their 60 cycle impedance. These high capacitance units are tested in the same fashion as other electrolytics but are read on the outer scale instead of the C₄ calibration.

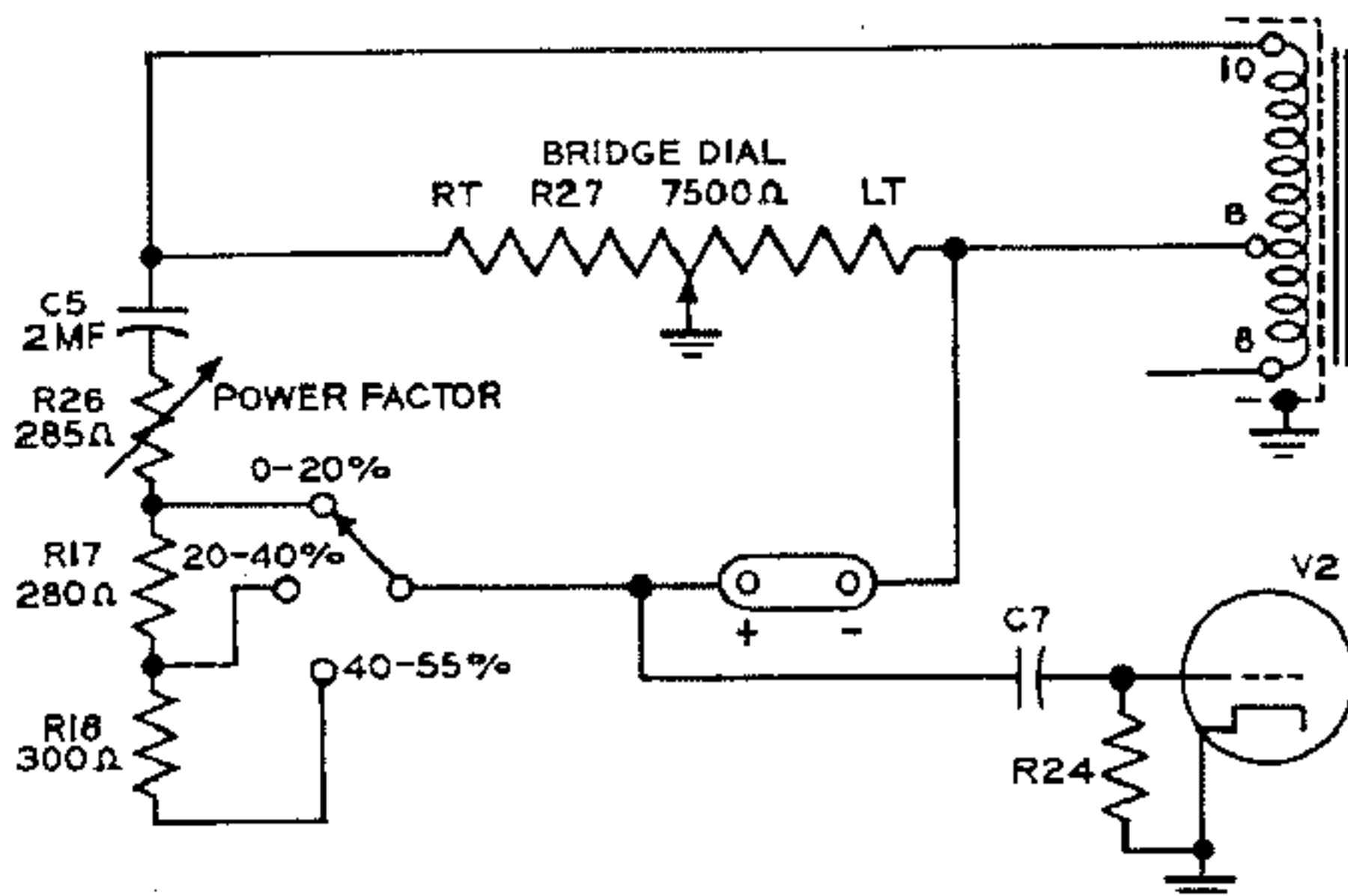

FIGURE 2

This Wien Bridge is used for measuring capacitance and power factor on Range C₃.

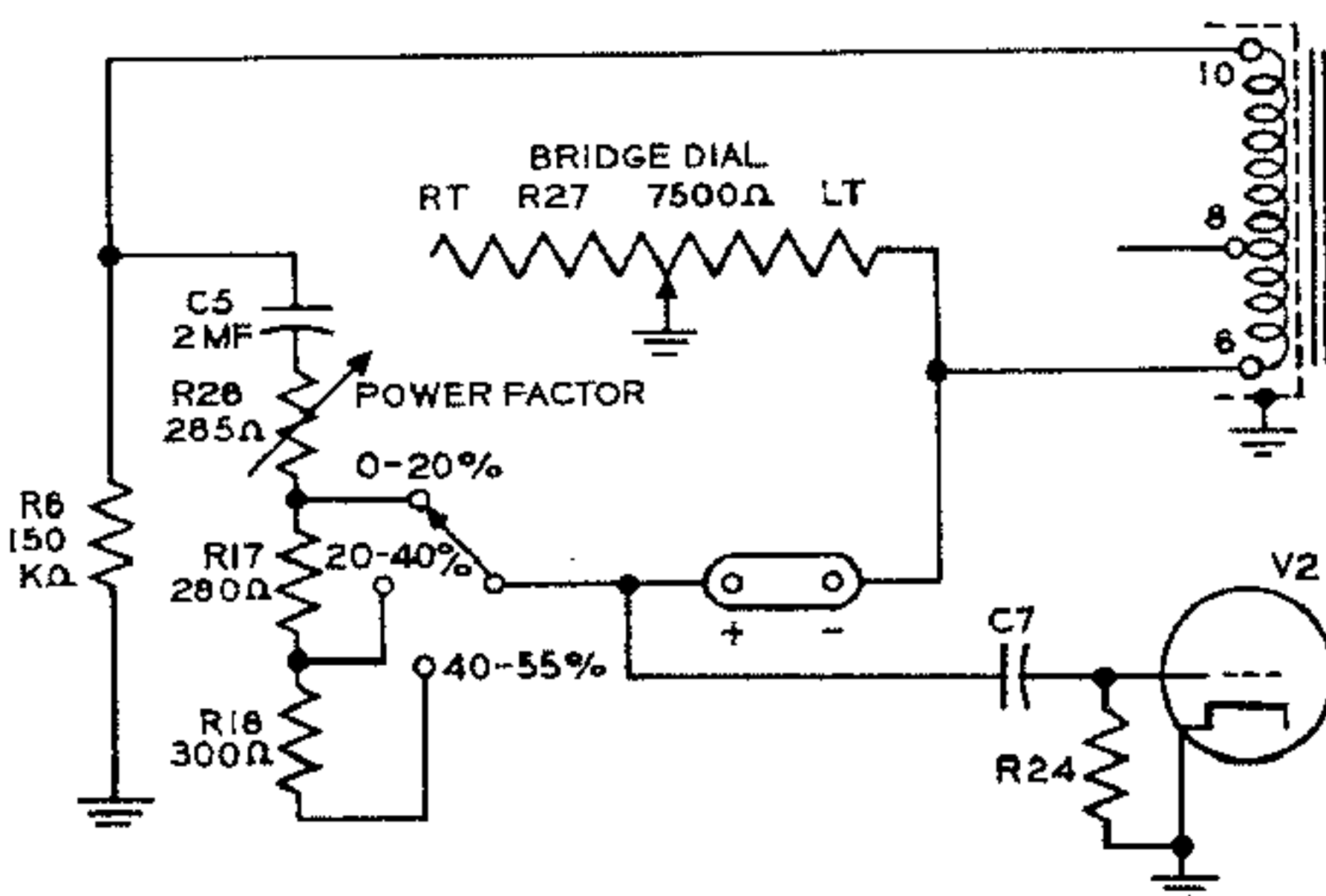

FIGURE 3

Here is how the measurement range of the Wien Bridge is extended for high capacitance electrolytics.

2.3 Capacitance Tolerance

2.3.1. D-C Dry Electrolytics. In general capacitors less than 75 percent of their nominal value should be replaced. In bypass capacitors, there is, from the application standpoint, usually no upper limit on the capacitance above nominal. This is also true of most filter capacitors except for the "reservoir" or input capacitors in power supplies. Here the upper capacitance limit depends on the permissible current thru the rectifier tube or dry disc rectifier. New dry electrolytics for TV-radio applications usually meet the following limits:

Rated Voltage	Percent Capacitance Tolerance
3-50	-10, +250
51-350	-10, +100
351-600	-10, +50

2.3.2 Paper Capacitors. Standard industry tolerances for paper tubulars when not otherwise specified or color-coded are usually as follows:

Capacitance (mf)	Tolerance (Percent)
Up to .0019	-25, +60
.002 to .009	-20, +40
.01 to .09	-20, +20
.1 to 1.0	-10, +20
Above 1.0	-10, +10

From the circuit application standpoint, the capacitance tolerances on coupling capacitors are usually more critical than those on bypass and filter capacitors. In radio receivers, units within the tolerances above are generally satisfactory in both types of use. In television sets, it is best to check the manufacturers service data since very tight tolerances are necessary in some specialized circuit locations.

2.3.3 Mica Capacitors. Non-color-coded or marked micas are usually $\pm 20\%$ units. Color-coded capacitors should fall within their marked tolerance.

2.3.4 Ceramic Capacitors. Temperature-compensating capacitors and other units using dielectric bodies with low dielectric constants are usually $\pm 20\%$ tolerance units, unless otherwise color coded or marked. High dielectric constant units may be of the $\pm 20\%$ type or else of the MRC (minimum rated capacitance) or GMV (guaranteed minimum value) type. These capacitors are usually used for bypass and coupling applications and their actual capacitance varies markedly with the ambient temperature at which they are measured. The rated minimum value is applicable only at 25°C (77°F) and the actual value may be double the MRC rating. Above room temperature capacitance may increase and then decrease, or decrease and then increase, according to the dielectric material used.

2.3.5 A-C Motor-Starting Electrolytics Capacitors more than 15% below the minimum marked capacity range should be replaced as the motor-starting torque will be seriously reduced.

2.4 Power Factor

2.4.1 D-C Dry Electrolytics The 60 cycle power factor of new capacitors will usually fall below the maximum value given below. Capacitors rated at 150 volts or higher should usually be replaced if the measured value is twice that given. Low voltage sections of multiple-section capacitors will generally have power factor higher than that listed, sometimes by as much as 50%.

WVDC	Max. New P-F	WVDC	Max. New P-F
450	15	150	20
400	15	50	25
350	15	25	30
300	15	15	50
250	18	12	55
		6	60

2.4.2 A-C Motor Starting Electrolytics Capacitors with a power factor of more than 15% should be replaced.

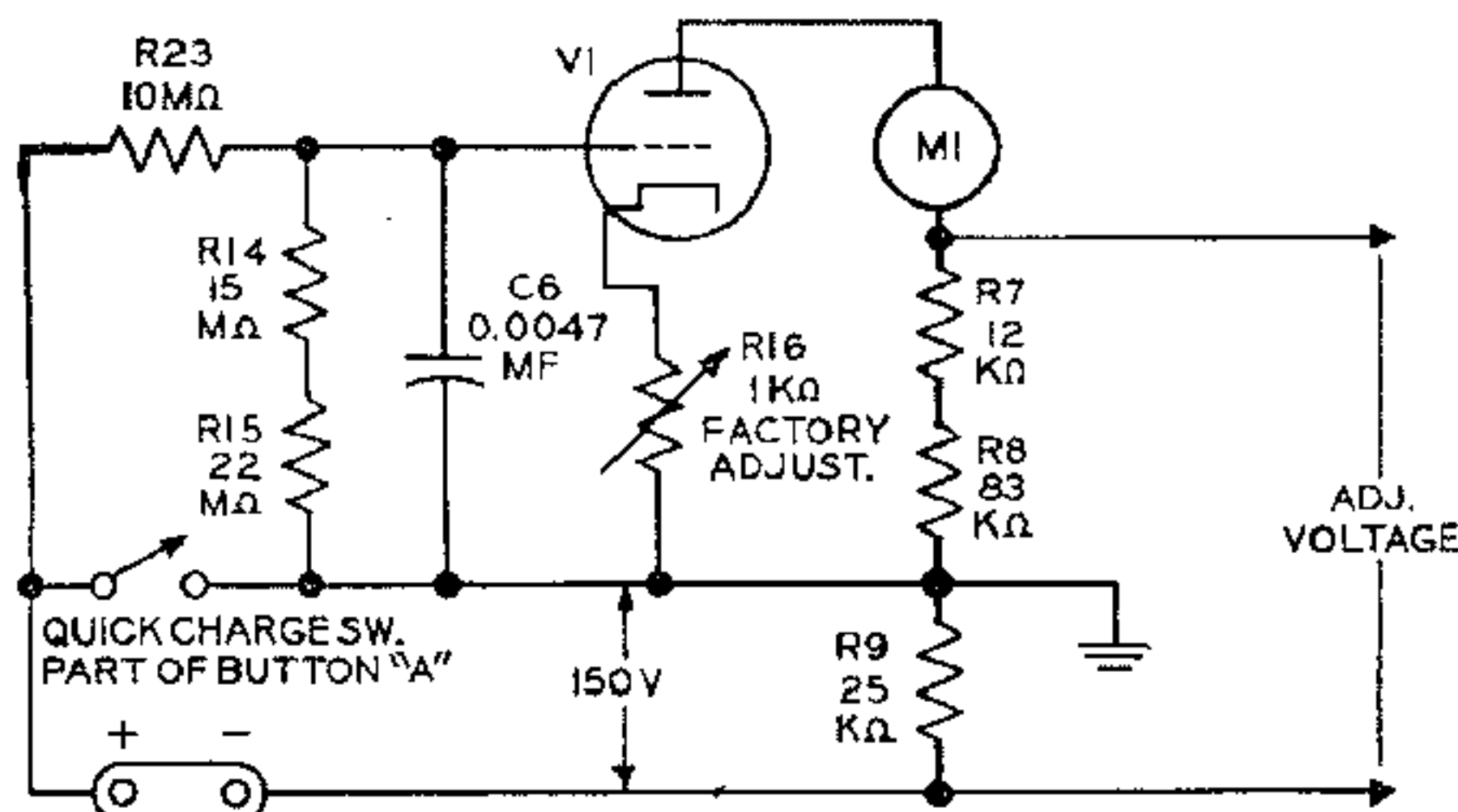

FIGURE 4

This is the insulation resistance measurement circuit with the new "Quick Charge" feature.

3. Insulation Resistance

3.1 The insulation resistance test is made only on electrostatic capacitors such as paper, mica, ceramic, etc. (Electrolytic capacitors are tested for leakage current as in section 4). The test circuit is shown in Figure 4. Passage of current thru the capacitor or other circuit element under test causes an increase in the negative bias on the grid of tube V_1 and a consequent decrease in plate current. The plate current meter is calibrated directly in megohms.

3.2 Operating Procedure

- (1) Depress pushbutton C
- (2) Place the voltage switch in the 600 position.
- (3) Set the bridge selector switch to the CAP. position.
- (4) Set the a-c line switch in the lower right hand corner of the panel to ON. Allow 1 minute warmup time.
- (5) Adjust the voltage control so meter reads SET.
- (6) Connect the capacitor under test to the binding posts.
- (7) If the capacitor under test is less than about .1 mf, the meter scale may be read almost immediately. For larger values of capacitance, depress pushbutton A for a few seconds and then release it. This permits the capacitor to charge more quickly without the large series limiting resistor in the circuit. Experience will soon guide the user as to how long to keep this button in. If the meter creeps up the capacitor is still not fully charged and the button should be depressed longer; a downward meter deflection indicates the button has been depressed too long. The insulation resistance is read from the meter scale after the pointer comes to rest or after 2 minutes have elapsed, whichever comes first. Wide fluctuations of the meter pointer indicate an intermittent capacitor which should be discarded.
- (8) After the test, release all pushbuttons to discharge the capacitor before you touch the terminals to remove the leads to the capacitor. Safety first!

3.3 Test Limits

3.3.1 Mica Capacitors. Standard molded micas will have an I-R when new of more than 3000 megohms while low-loss case and silvered micas will have an I-R when new of at least 6000 megohms.

3.3.2 Ceramic Capacitors. Most ceramic capacitors rated at .02 mf or less when new will have a minimum insulation resistance of 7,500 megohms.

3.3.3 Paper Capacitors. The minimum insulation resistance times capacitance product for paper tubular capacitors is 1000 megohm-microfarads when new except that capacitors are in no case required to have an insulation resistance of more than 5000 megohms, as per the following table. Molded tubulars will usually exceed these minimum limits by a wide margin.

<u>Capacitance</u>	<u>Minimum IR</u>
1.0 mf	1000 megohms
.5	2000
.47	2128
.25	4000
.22	4545
.15	5000
.1 or smaller	5000

Insulation resistance measurements are very much affected by ambient temperature. An ordinary wax tubular will have an I-R at 65°C of about 5 percent of its 25°C (77°F) value. For metal-encased oil capacitors, the minimum values vary from 400 megohm-mf (or 1200 megs. max. req.) for castor oil, to 1500 megohm-mf (or 4000 megs. max. req.) for mineral oil, to 1500 megohm-mf (or 4000 megs. max. req.) for Aroclors, to 20,000 megohm-mf (or 30,000 megs. max. req.) for some designs of Vitamin Q subminiature capacitors. These values are given as a general guide and change somewhat with different manufacturers and different physical sizes of units.

3.4 The insulation resistance circuit may also be used in checking motor windings, high value resistors in photocell and nuclear instrument circuits, leakage between posts on terminal strips, etc.

4. Leakage Current of Electrolytic Capacitors.

4.1 The test circuit shown in Figure 5 permits measurement of leakage current of electrolytic capacitors. The self-contained power supply provides any desired test voltage up to 600 volts d-c. To facilitate accurate adjustment of the lower voltages, a low voltage range of 60 volts max. is provided in addition to the 600 volt max. circuit. The meter reads the actual voltage applied to the capacitor terminals since the limiting resistor (which limits the current thru short-circuited capacitors to 60 ma.) is in the cathode circuit of the grid-controlled rectifier tube. Two meter ranges are provided to protect against burnouts, an initial range of 0-60 ma and a final reading range of 0-6 ma.

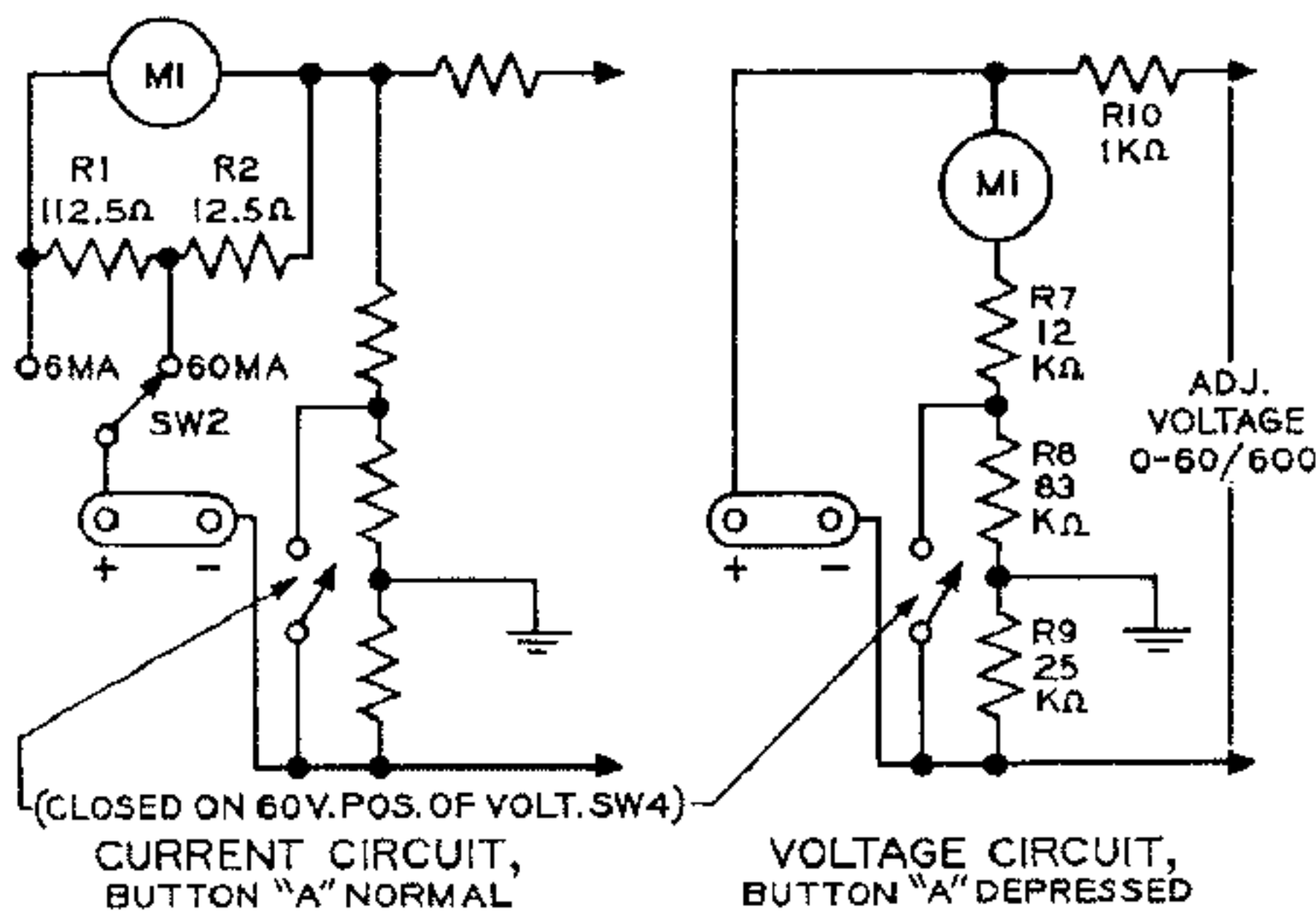
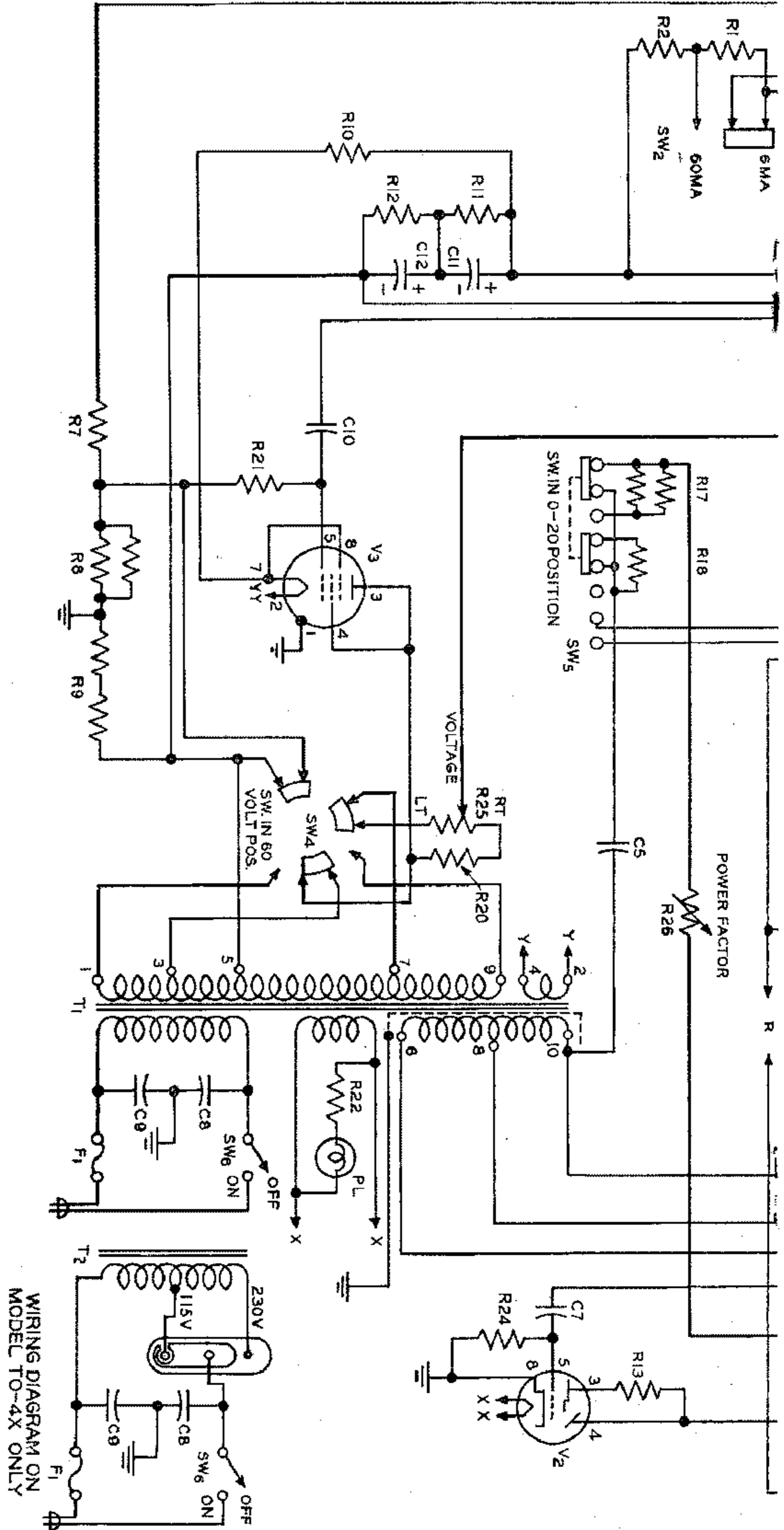

FIGURE 5

This is the basic arrangement for measuring the leakage current of electrolytic capacitors.

4.2 Operating Procedure

- (1) Turn voltage control to the OFF position.
- (2) Depress button B.
- (3) Set the bridge selector switch in the CAP. position.
- (4) Set the electrolytic leakage switch in the 60 MA position.
- (5) Turn the voltage switch at the lower right to the 60 position for capacitors with a voltage rating up to 60 wvdc or to the 600 position for units with a higher working voltage.
- (6) Set the a-c line switch to ON. Allow 1 minute warm-up time.
- (7) Connect capacitor to be tested across the binding posts, observing proper polarity.



CIRCUIT DIAGRAM

MODEL TO-4 TEL-OHMIKE

WIRING DIAGRAM ON MODEL TO-4X ONLY

PRESS TO READ VOLTS
 CHARGE
 A
 ELECTROLYTIC LEAKAGE
 B
 INSULATION RESISTANCE
 C
 0.000001-0.005
 C1 & C5
 R1
 2.5-2500
 D
 0.001-0.5
 C2
 R2
 250-250K
 E
 0.1-50
 C3
 R3
 25K-25MEG.
 F
 45-2K
 C4
 SW. IS SHOWN WITH ALL BUTTONS IN RELEASED POSITION (OUT)
 G

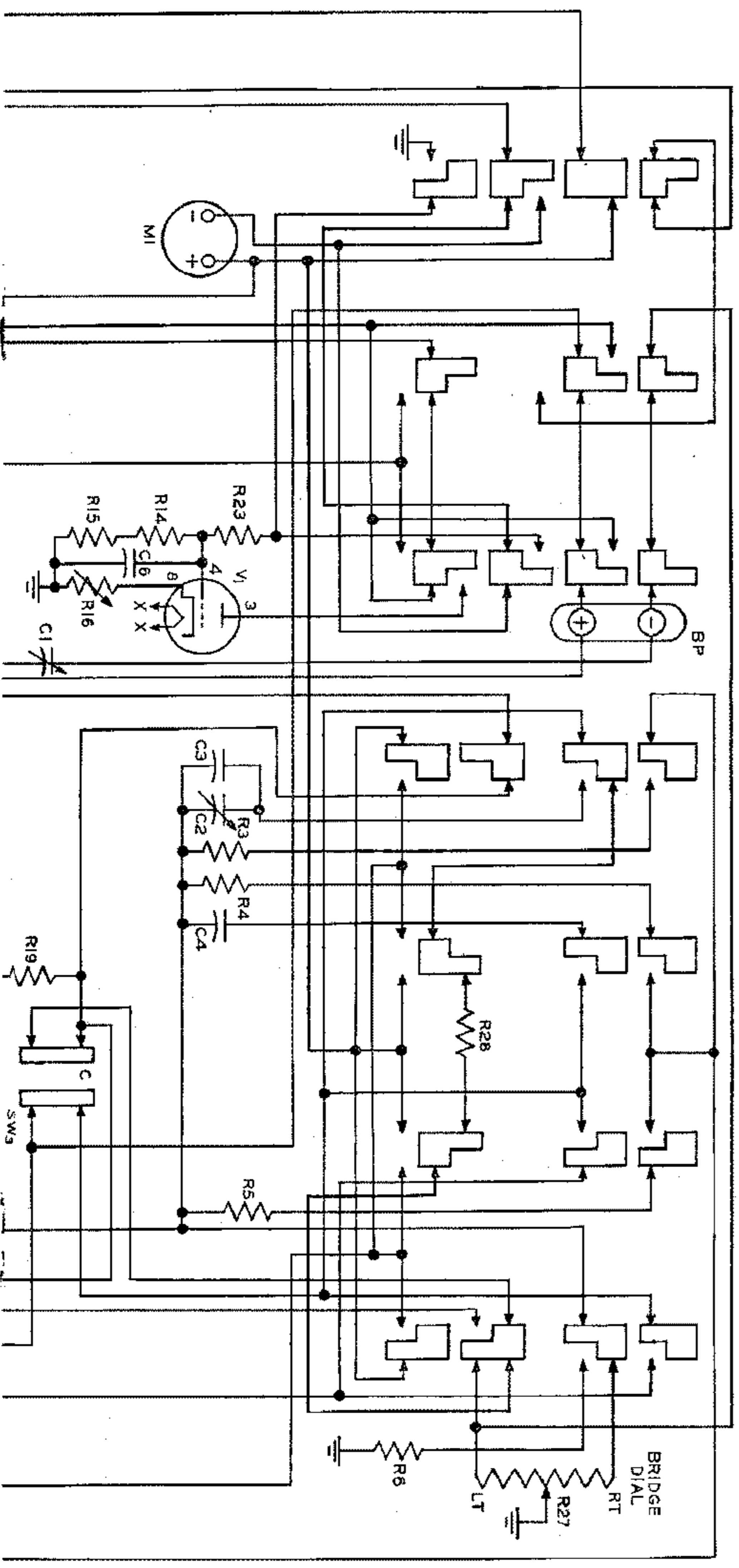

- (8) Hold in button A and adjust the voltage control until the meter reads the correct capacitor working voltage on the 600 scale. Divide the scale reading by 10 when using the 60 position of the voltage range switch.
- (9) Release button A and read the leakage current on the 600 scale of the meter. Divide the reading by 10 to get the leakage current in milliamperes if using the 60 MA switch position or by 100 if using the 6 MA position. If the reading on the 60 MA position is less than 6 milliamperes, push the range switch up to 6 MA and read the current with increased accuracy.
- (10) Release button B to discharge the capacitor before removing it from the binding posts. Safety First!

4.3 It will be noted that the voltage reading (with button A depressed) will tend to increase after a short time as the leakage current begins to decrease to a stable value. The voltage control should be retarded accordingly to prevent more than rated voltage from being applied to the capacitor. The measurement of leakage current should be made only after a stable value is reached. Capacitors which have been out of use for periods of a year or more may take as long as 30 minutes to reach a stable value of leakage current. Such capacitors usually have a high current initially and the voltage control should be retarded so that the leakage current is less than 10 milliamperes in order to prevent overheating of the capacitors internally. The voltage should be adjusted upwards until rated voltage is reached as the leakage current decreases. When rated voltage is finally reached, proceed as detailed above. If there is appreciable fluctuation in the leakage current indication, the capacitor is probably intermittent and should be discarded.

4.4 Test Limits. New radio-TV type electrolytics should have a maximum leakage current as shown in the following table:

<u>3 — 100 WVDC</u>		<u>101-250 WVDC</u>	
<u>mf</u>	<u>ma</u>	<u>mf</u>	<u>ma</u>
1	.31	4	.38
2	.32	8	.46
5	.35	10	.54
10	.4	12	.54
20	.5	15	.6
25	.55	16	.62
30	.6	20	.7
40	.7	30	.9
50	.8	40	1.1
70	1.0	50	1.3
80	1.1	60	1.5
100	1.3	70	1.7
125	1.55	80	1.9
130	1.6	100	2.3
150	1.8	120	2.7
200	2.3	125	2.8
250	2.3	140	3.1
500	5.3	150	3.3
1000	10.	200	4.3
1500	10.	300	6.3
2000	10.		
3000	10.		

<u>251-350 WVDC</u>		<u>351-500 WVDC</u>	
<u>mf</u>	<u>ma</u>	<u>mf</u>	<u>ma</u>
4	.3	2	.38
8	.5	4	.46
10	.55	5	.5
12	.6	8	.62
15	.68	10	.7
16	.7	12	.78
20	.8	15	.9
30	1.05	16	.94
35	1.18	20	1.1
40	1.3	25	1.3
50	1.55	30	1.5
60	1.8	40	1.9
80	2.3	50	2.3
100	2.8	60	2.7
120	3.3	80	3.5
125	3.43	90	3.9
150	4.05	125	5.3
200	5.3		

Maximum leakage currents not shown in above table may be derived from the following formula:

$$I = kC + 0.3$$

where I is the leakage in milliamperes

k is a constant as follows:

<u>k</u>	<u>WVDC</u>
.01	3 to 100
.02	101 to 250
.025	251 to 350
.04	351 to 500

C is the nominal capacitance in mf.

Readings should be taken 5 minutes after capacitors are placed on rated d-c working voltage. These limits may be used as a guide in judging whether capacitors should be replaced, making due allowance for the usual increase in leakage current with age and with any high ambient temperature at which measurements are made. Capacitors with a leakage current of more than 15 ma should almost always be discarded.

5. Resistance Measurements

5.1 The basic circuit for the three range line-frequency bridge is shown in Figure 6.

5.2 Operating Procedure

- (1) Place the bridge selector switch in the RES position.
- (2) Depress the proper pushbutton in accordance with the following table:

<u>Resistance</u>	<u>Pushbutton</u>	<u>Read on Scale</u>
2.5 to 2500 ohms	D	R ₁
250 to 250K ohms	E	R ₂
.025 to 25 megohms	F	R ₃

- (3) Place voltage switch in 600 position.
- (4) Set the a-c line switch to ON. Allow 1 minute warm-up time.
- (5) Place resistor to be tested across binding posts.
- (6) Rotate the center knob until the magic eye has maximum shadow opening. Read the resistance directly from the pointer on the calibrated scale.

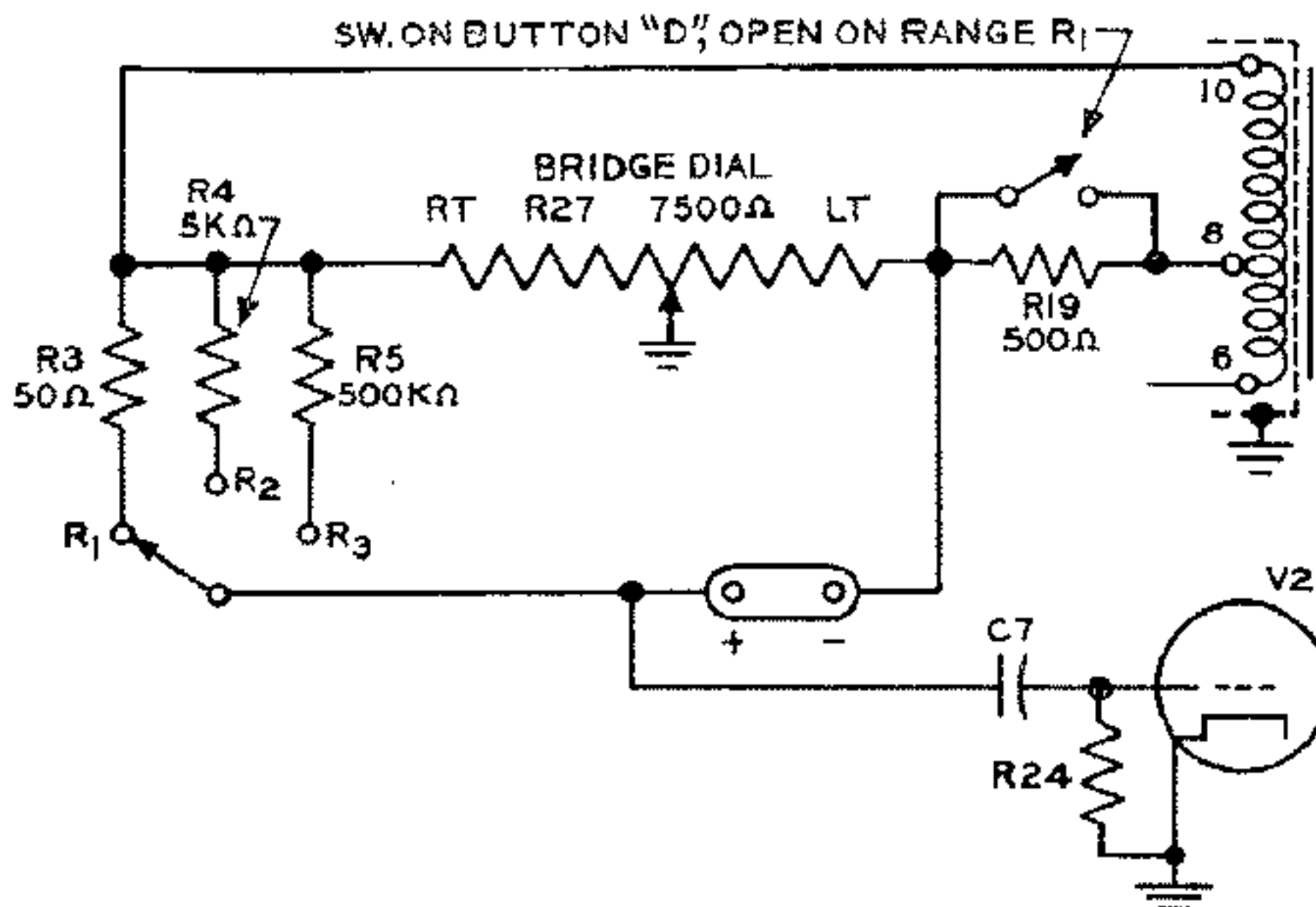

FIGURE 6

This is the 3 range a-c Wheatstone resistance bridge for checking resistors.

6. Miscellaneous Hints

- 6.1** The eye tube glows only when the bridge portions of the Tel-Ohmike are used (buttons D,E,F,G). It does *not* glow when measuring insulation resistance or leakage current.
- 6.2** To avoid parallax error, always read the main dial pointer with your eye directly in front of the pointer. Reading from an angle at the side will introduce errors.
- 6.3** For maximum accuracy of reading when there is a choice of bridge scales, always use the measurement range which will give a scale reading nearest the center of the scale arc.
- 6.4** The maximum accuracy of readings on electric indicating instruments (meters) is over the upper portion of the scale arc.
- 6.5** Resistance readings on this a-c bridge and those on a d-c ohmmeter will not necessarily agree, especially if the ohmmeter readings are on the lower part of its meter scale if the resistor is of the wirewound type with considerable self-inductance.
- 6.6** Return your Tel-Ohmike Registration Card within 5 days of the date of purchase in order to obtain the benefits of the Sprague warranty.
- 6.7** Always give *model* and *serial number* of your Tel-Ohmike, when corresponding concerning your instrument. You will find the serial number on the rear of the chassis below the line cord.
- 6.8** If it should ever be necessary to return your TO-4 for service or recalibration, write for detailed shipping instructions to your nearest authorized service depot. You will save time and money by this procedure!

LIST OF MAINTENANCE PARTS

Circuit Symbol	Replacement Part No.	Description
C ₁ } C ₂ }	1-1001	Capacitor, adjustable dual trimmer silver ceramic 4-30 mmf.
C ₃	1-833	Capacitor, fixed, silver-mica dielectric, 180 mmf $\pm 5\%$, 500 vdc, Sprague type 14.
C ₄	1-202A	Capacitor, fixed, molded paper-dielectric, .02 mf $\pm 2\%$ 400 vdc. Consists of 1 each Sprague type 67P-.018 mf and .0018 mf matched in parallel to value.
C ₅	1-208	Capacitor, fixed, paper-dielectric, 2. mf $\pm 2\%$ 400 vdc. Consists of two Sprague No. 1.004AG matched in parallel to value.
C ₆	1-832	Capacitor, fixed, molded paper-dielectric, .0047 mf $\pm 20\%$ 400 vdc. Sprague No. 67P47204
C ₇ } C ₈ } C ₉ } C ₁₀ }	1-830	Capacitor, fixed, molded paper-dielectric, .018 mfd $\pm 10\%$ 400 vdc. Sprague No. 67P18394.
C ₁₁ } C ₁₂ }	1-660	Capacitor, fixed, polarized dry electrolytic, 12 mf, 450 vdc. insulating jacket. Sprague type DEE with 2R center mounted horizontal strap.
M ₁	7-10	Milliammeter, 0-5 ma d-c $\pm 2\%$ special scale, internal res. 25 ohms $\pm 2\%$.
F ₁	7-501	Fuse, cartridge, 1 amp., type 3AG.
PL	5-47	Pilot Lamp, No. 47.
V ₁	5-12J5	Tube, electron, 12J5GT.
V ₂	5-1629	Tube, electron, 1629
V ₃	5-1619	Tube, electron, 1619.
R ₁	2-662	Resistor, fixed, wire-wound, 112.5 ohms $\pm 2\%$, 1 watt.
R ₂	2-660	Resistor, fixed, wire-wound, 12.5 ohms $\pm 2\%$, 1 watt.
R ₃	2-661	Resistor, fixed, wire-wound, 50 ohms $\pm 2\%$, 1 watt.
R ₄	2-66A	Resistor, fixed, deposited-carbon, 5000 ohms $\pm 2\%$, $\frac{1}{2}$ watt.
R ₅	2-112A	Resistor, fixed, deposited-carbon, 500,000 ohms $\pm 2\%$, $\frac{1}{2}$ watt.
R ₆	2-101A	Resistor, fixed, deposited-carbon, 150,000 ohms $\pm 2\%$, $\frac{1}{2}$ watt.
R ₇	2-324A	Resistor, fixed, composition, 12,000 ohms $\pm 2\%$, 1 watt. May have a resistor in series or parallel to bring to value.
R ₈	2-601	Resistor, fixed, composition, 83,000 ohms $\pm 2\%$, 4 watts. Consists of two 2 watt resistors in parallel.
R ₉	2-331	Resistor, fixed, composition, 25,000 ohms $\pm 2\%$, 2 watts. Consists of two 1 watt resistors in series.

LIST OF MAINTENANCE PARTS—Continued

Circuit Symbol	Replacement Part No.	Description
R ₁₀	2-698	Resistor, fixed, wire-wound, 1000 ohms $\pm 5\%$, 5 watts. Sprague Koolohm type 5KT.
R ₁₁ } R ₁₂ } R ₁₃ }	2-113	Resistor, fixed, composition, 470,000 ohms $\pm 10\%$, $\frac{1}{2}$ watt.
R ₁₄	2-149	Resistor, fixed, composition, 15 megohms $\pm 10\%$, $\frac{1}{2}$ watt.
R ₁₅	2-153	Resistor, fixed, composition, 22 megohms $\pm 10\%$, $\frac{1}{2}$ watt.
R ₁₆	2-1032	Resistor, continuously adjustable, 1000 ohms $\pm 20\%$, 1.5 watts. Screwdriver adjustment.
R ₁₇	2-43A	Resistor, fixed, composition, 280 ohms $\pm 10\%$, 1 watt. Consists of two $\frac{1}{2}$ watt resistors in parallel.
R ₁₈	2-36	Resistor, fixed, composition, 300 ohms $\pm 5\%$, $\frac{1}{2}$ watt.
R ₁₉	2-791	Resistor, fixed, wire-wound, 500 ohms $\pm 5\%$, 10 watts. Sprague Koolohm type 10KT.
R ₂₀	2-365	Resistor, fixed, composition, 560,000 ohms $\pm 10\%$, 1 watt.
R ₂₁	2-121	Resistor, fixed, composition, 1 megohm $\pm 10\%$, $\frac{1}{2}$ watt.
R ₂₂	2-266	Resistor, fixed, wire-wound 47 ohms $\pm 20\%$, 1 watt.
R ₂₃ } R ₂₄ }	2-145	Resistor, fixed, composition, 10 megohms $\pm 10\%$, $\frac{1}{2}$ watt.
R ₂₅	2-1003	Resistor, continuously adjustable, composition, 500,000 ohms $\pm 20\%$, linear taper, $\frac{1}{2}$ watt.
R ₂₆	2-1031	Resistor, continuously adjustable, wire-wound 285 ohms $\pm 10\%$, linear taper, 2 watts, 300° mechanical rotation, 280° electrical rotation.
R ₂₇	2-1020	Resistor, continuously adjustable, wirewound 7500 ohms $\pm 10\%$, linear taper, 3 watts. 300° mechanical rotation, 280° electrical rotation. Picked for agreement with scale. May have make up resistors.
R ₂₈	2-1	Resistor, fixed, wire-wound, 10 ohms $\pm 20\%$, $\frac{1}{2}$ watt.
SW ₁	11-51	Switch, 7 push-button
SW ₂	11-80	Switch, slide, spdt
SW ₃	11-82	Switch, slide, dpdt
SW ₄	11-159	Switch, rotary, 3 pole, 2 position
SW ₅	11-81	Switch, slide, 2 pole, 4 position
SW ₆	11-76	Switch, slide, spst
BP	15-303	Binding post assembly.
T ₁	3-91	Transformer, filament, power and bridge supply, for TO4
T ₁	3-91X	Transformer, filament, power and bridge supply, for TO-4X

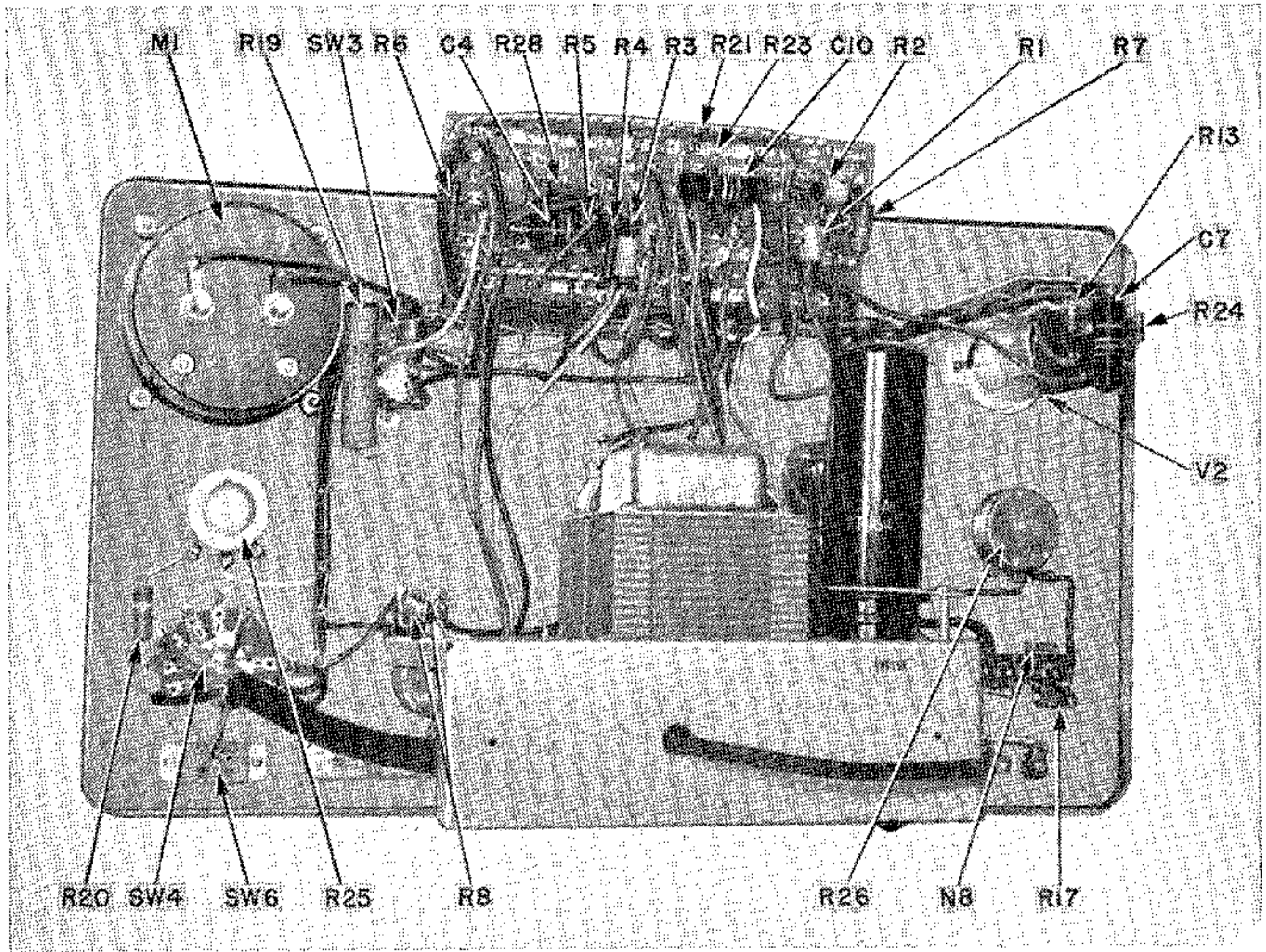

VIEW FROM LEFT REAR

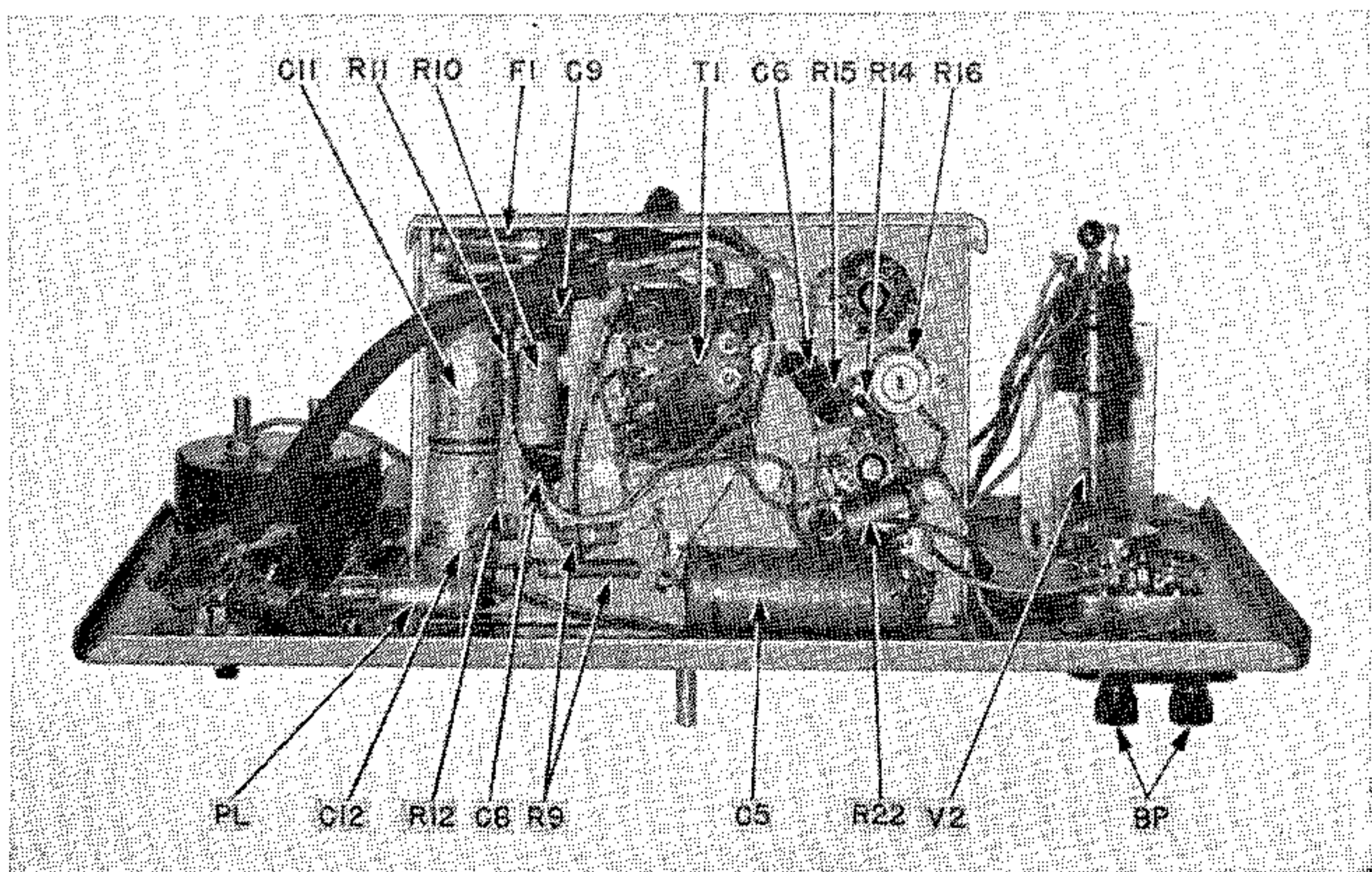

BOTTOM VIEW OF CHASSIS

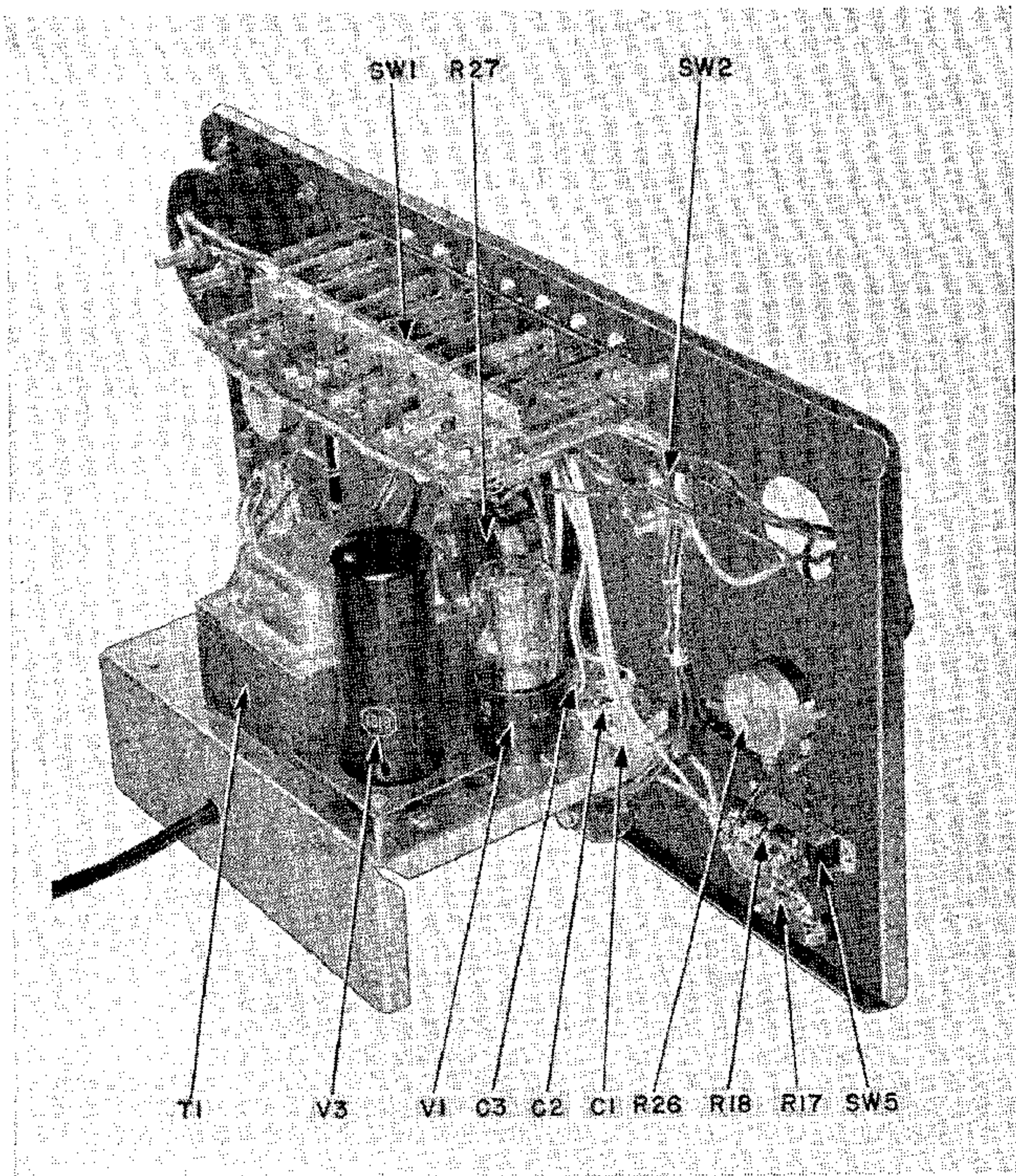

VIEW FROM RIGHT REAR

STANDARD MODEL TO-4 WARRANTY

The Sprague Products Company warrants each Tel-Ohmike Analyzer to be free from defective material and workmanship and agrees to remedy any such defect or to furnish a new part in exchange for any part of any unit of its manufacture which under normal installation, use and service discloses such defect, provided the unit is delivered by the owner to us intact, for our examination, with all transportation charges prepaid to our factory or authorized service station within ninety days from the date of sale to original purchaser and provided that such examination discloses in our judgment that it is thus defective.

This Warranty does not extend to any Tel-Ohmike which has been subjected to misuse, neglect, accident, incorrect wiring not our own, improper installation, or to use in violation of instructions furnished by us, nor extend to units which have been repaired or altered outside of our factory nor to cases where the serial number thereof has been removed, defaced or changed.

Any part of a unit approved for remedy or exchange hereunder will be remedied or exchanged by us without charge to the owner.

This Warranty is in lieu of all other Warranties expressed or implied and no representative or person is authorized to assume for us any other liability in connection with the sale of our products.

If the return of this instrument is deemed necessary, advise SPRAGUE PRODUCTS COMPANY, NORTH ADAMS, MASS., giving full details. Our reply and complete shipping instructions will reach you within five (5) days after receipt of your letter. **NO ADJUSTMENTS WILL BE MADE UNLESS OUR CONSENT FOR THE RETURN OF THE INSTRUMENT IS OBTAINED BEFORE MAKING SHIPMENT.**

NOTE: RETURNED INSTRUMENTS MUST BE PACKED CAREFULLY, MARKED FRAGILE, AND SHIPPED BY PREPAID EXPRESS.

SPRAGUE PRODUCTS COMPANY
North Adams, Mass.